



Montageanleitung
Instructions de montage
Assembly instruction

GreenBlock 160

Jakob
Rope Systems

Montageanleitung GreenBlock 160

Der GreenBlock 160 ist eine thermisch getrennte Hochlastkonsole, ausgelegt zum Lastabtrag der Maximallasten der Distanzhalter Webnet.

Die Montage beinhaltet das Aufschneiden der bestehenden Fassade, die Verankerung des GreenBlocks 160 und des Distanzhalters sowie die Abdichtung der Durchdringung.

Allgemeine Hinweise

Auf ausreichende Tragfähigkeit des Untergrunds zur Einleitung der auftretenden Kräfte ist zu achten.

Montage der Bauteile nur durch geschultes Personal.

Es wird keine Haftung für die notwendigen Sicherheitsvorkehrungen zur fachgerechten Montage übernommen. Es wird keine Verantwortung für die Sicherheit und Unversehrtheit aller beteiligten Personen und der Umgebung übernommen.

Werkzeug

- 01 Doppelmeter
- 02 Marker
- 03 Schlagbohrmaschine
- 04 Bohrer Ø 14 mm
- 05 Schraubenzieher
- 06 Hammer
- 07 Ausblaspumpe
- 08 Stahlrundbürste
- 09 Handpistole
- 10 Verlängerungsrohr
- 11 Sechskant-Nuss
- 12 Akku-Bohrmaschine
- 13 Torx 25
- 14 Staubsauger

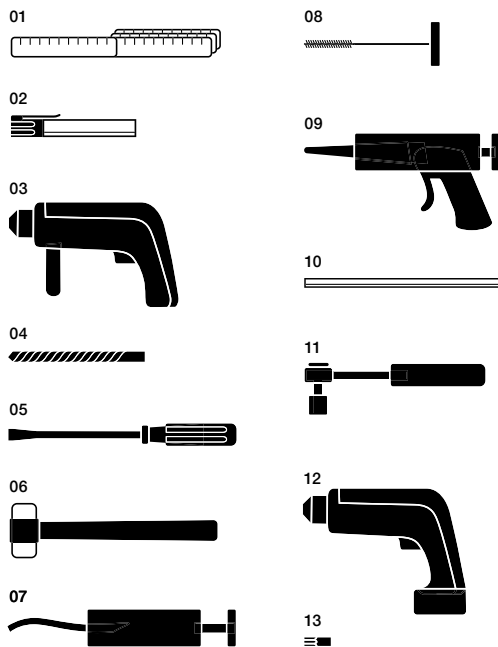

Nicht im Lieferumfang enthalten.

Werkzeug Jakob

- 15 Kreisschneider
- 16 Frästeller
- 17 Fräsglocke
- 18 Mitnehmer

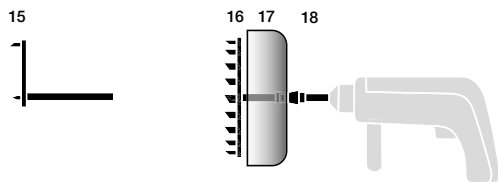

Werkzeug Jakob nicht im Lieferumfang. Erhältlich über Ihren Jakob-Kontakt vor Ort: jakob.com (Nr. 30805-0010). Nur für EPS-, Glas- und Steinwolle-Dämmung geeignet.

Bauteile GreenBlock 160

- 19 1 × Aufdoppelung (optional)
Nr. 30805-0160-...
- 20 1 × Grundkörper
Nr. 30805-0160-...
- 21 3 × EPS-Rondellen klein
Nr. 30805-0125-005
- 22 3 × Sicherungsmuttern M12
Nr. 30892-1200-02
- 23 3 × Unterlegscheiben
Nr. 30896-1200-30
- 24 3 × Gewindestifte M12
Nr. 30882-1200-...
- 25 1 × Verbundmörtel
Nr. 30803-0800-05
- 26 1 × Distanzhalter Webnet
Nr. 30897-...-00
- 27 3 × Sechskantschrauben M12
Nr. 30843-1200-025
- 28 3 × Unterlegscheiben M12
Nr. 30896-1200-30
- 29 3 × Linsensenk-Fassaden-
schrauben Ø 4,5 mm
Nr. 30841-0450-080-01
- 30 1 × Abdeckblech
Nr. 30805-0160-007
- 31 1 × Butylband (optional)
Nr. 30805-0160-003

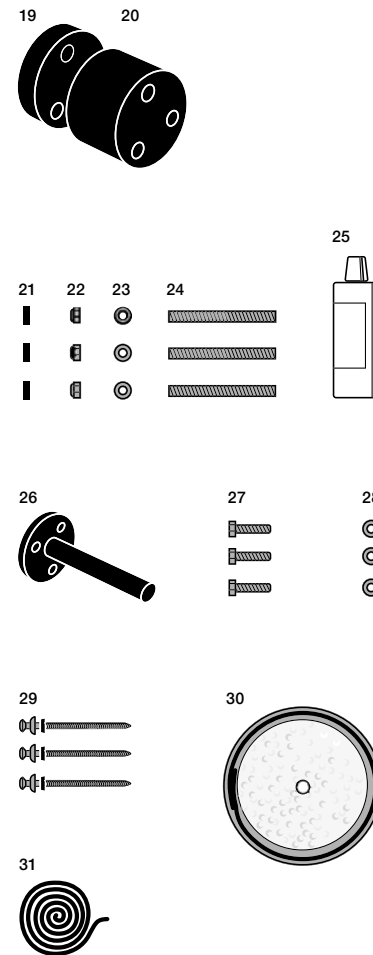

Bauteile Nr. 25, 26 und 31 nicht im Lieferumfang. Erhältlich über Ihren Jakob-Kontakt vor Ort: jakob.com

1

Aussenputz aufschneiden und entfernen

- 1.1 Aussenputz mit Kreisschneider und Fräsglocke bei angezeichneter Position aufschneiden.
 1.2 Freigeschnittene runde Fläche mit geeignetem Werkzeug entfernen.

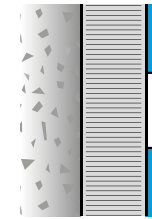
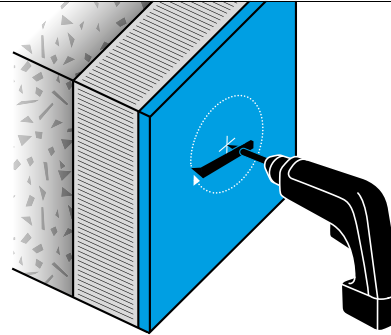

Aussenputz nicht beschädigen!

2

Isolation wegfräsen

- 2.1 Isolation rechtwinklig zur Aussenwand mit Frästeller und Fräsglocke wegfräsen.

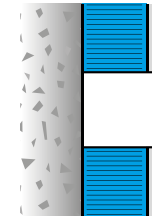
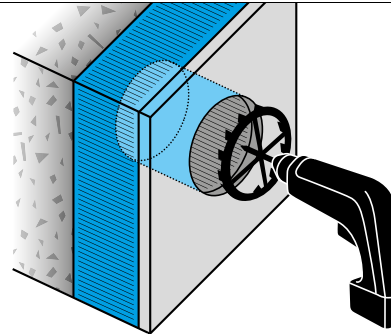

3

Betonoberfläche reinigen und ausebnen

- 3.1 Freigelegte Betonoberfläche von Isolationsresten befreien.
 3.2 Unebenheiten entfernen.

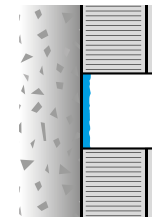
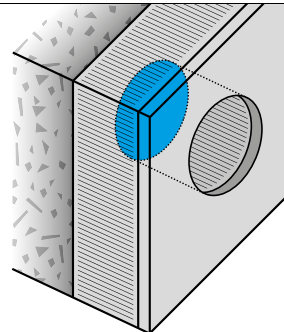

4

X-Mass messen

4.1 X-Mass für die Bestimmung der Bohrtiefe messen.

X = _____ mm

⚠
X-Mass ist die Distanz von freigelegter Betonoberfläche bis zur Putz-Aussenkante.

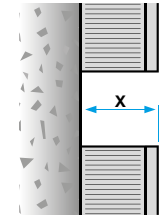
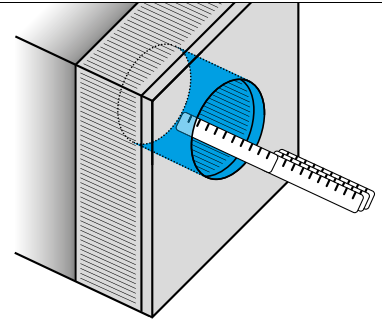

5

Ausgleichsmörtel mit Grundkörper platzieren

- 5.1** Grundkörper mit Aufdoppelung (falls mitgeliefert) zusammenfügen.
- 5.2** Mörtel auf Unterseite auftragen, um Unebenheiten auszugleichen.
- 5.3** Grundkörper in Loch einschieben und Mörtel aushärten lassen. Aushärtezeit gemäss Herstellerangabe.

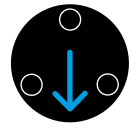
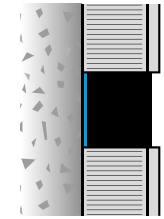
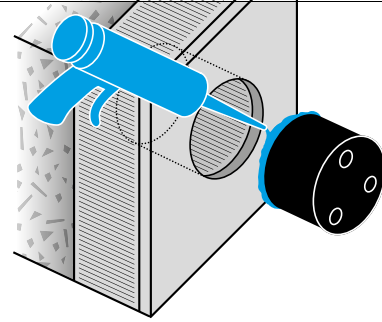

Lastrichtung

⚠
Aushärtezeit beachten!

6

Löcher bohren

- 6.1** L-Mass gemäss Tabelle definieren.
- 6.2** Bohrer mit L-Mass markieren.
- 6.3** Löcher bohren, bis die Markierung vom Bohrer auf der Höhe der Putz-Aussenkante ist.
- 6.4** Gewindestifte einstecken, um Bohrlochtiefe nachzuprüfen.

X-Mass (mm)	L-Mass (mm)	Betonmindestdicke (mm)
> 120	245	155
> 140	270	160
> 160	297	170
> 180	325	175
> 200	351	185
> 220	378	190
> 240	405	195
> 260	X + 161	205

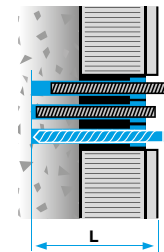
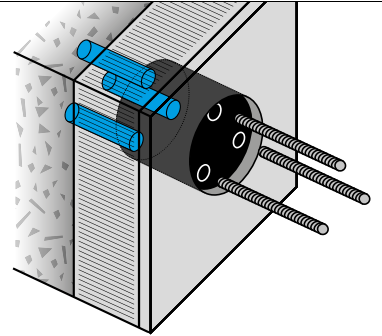

⚠
Betonmindestdicke gemäss Tabelle einhalten!

7

Bohrlöcher reinigen

- 7.1** Gewindestife entfernen.
7.2 Bohrlöcher gemäss Produktangaben des Injektionsmörtels reinigen.

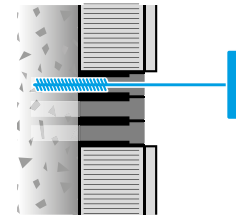
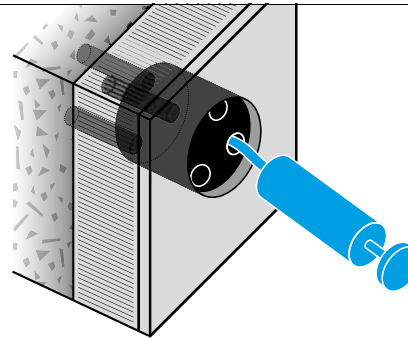

8

Gewindestifte einkleben

- 8.1** Sicherungsmutter minimal auf Gewindestift aufdrehen und Unterlegscheibe über Gewindestift stülpen.
8.2 Erstes Bohrloch mit Injektionsmörtel füllen.
8.3 Gewindestift in Bohrloch eindrehen und beachten, dass Gewindestift nicht über den Grundkörper hinaussteht. Mörtel aushärten lassen. Aushärtezeit gemäss Herstellerangabe.
8.4 Schritte 8.1–8.3 für die anderen Verankerungen wiederholen.

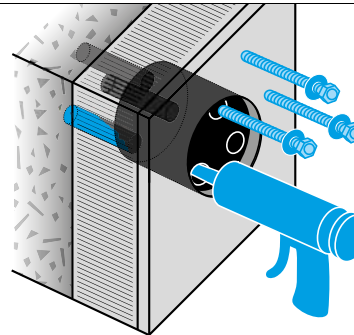

⚠ Aushärtezeit beachten!

9

Gewindestifte anziehen

- 9.1** Gewindestife mit 65 Nm Anzugsdrehmoment anziehen.
9.2 Mit EPS-Rondellen die Gewindestife überdecken.

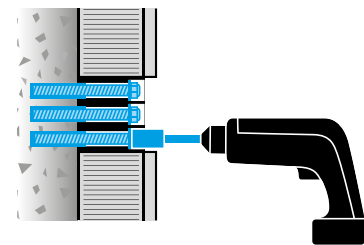
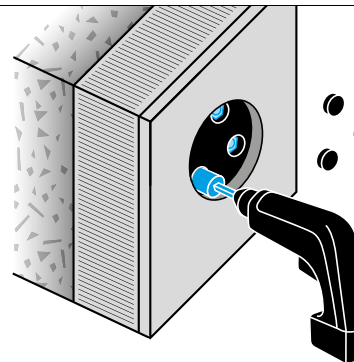

10

Distanzhalter Webnet befestigen

10.1 Distanzhalter Webnet mit 65 Nm Anzugsdrehmoment anziehen.

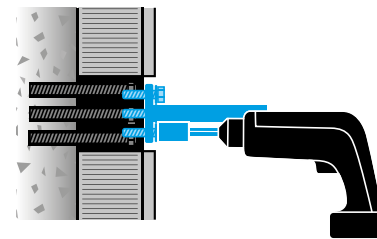
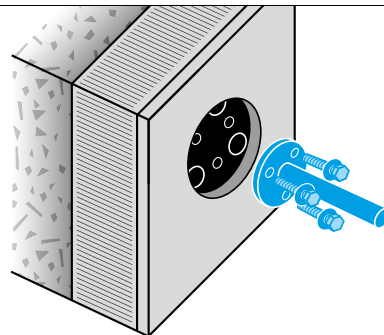

11

Putzoberfläche reinigen

11.1 Putzoberfläche mit Lösungsmittel reinigen.
11.2 Für Grobputz muss auf dem Abdeckblech ein zusätzliches Butylband auf dem vormontierten Band angebracht werden.

⚠ Die beiden Dichtungsbänder lückenlos miteinander verbinden.

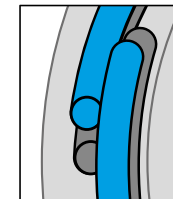
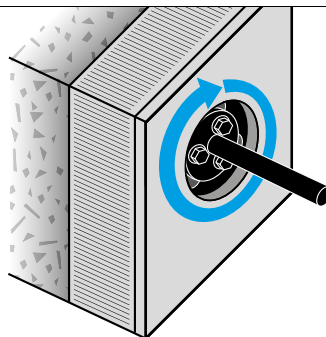

12

Abdeckblech befestigen

12.1 Abdeckblech über Distanzhalter stülpen.
12.2 Abdeckblech mit Linsenk-Fassadenschraube in Zentrierungsmulden anschrauben.

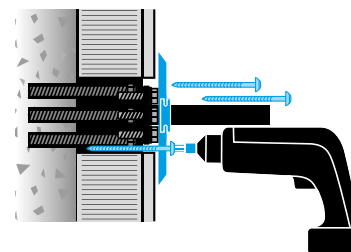
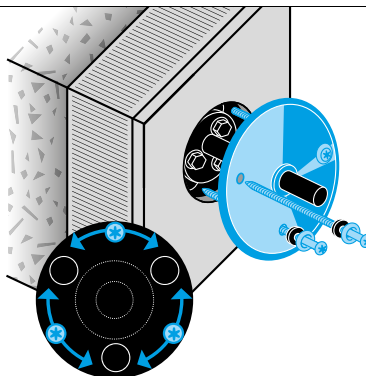

⚠ Bohrmaschine auf niedrige Stufe schalten!

Instructions de montage du GreenBlock 160

Le GreenBlock 160 est une console pour charges élevées à rupture de pont thermique, conçue pour supporter les charges maximales des entretoises Webnet.

Le montage comprend la découpe de la façade existante, l'ancrage du GreenBlock 160 et de l'entretoise ainsi que l'étanchéité de la pénétration.

Consignes générales

Il faut veiller à ce que la capacité de charge du support soit suffisante pour transférer les forces en présence.

Le montage des composants doit être assuré exclusivement par du personnel formé.

Aucune responsabilité n'est assumée en ce qui concerne les mesures de sécurité nécessaires pour un montage dans les règles de l'art. Aucune responsabilité n'est assumée pour la sécurité et l'intégrité de toutes les personnes concernées et de l'environnement.

Vidéo de montage: [jakob.com](https://www.jakob.com) > Downloads > Vidéos

Outil

- 01 Double-mètre
- 02 Marqueur
- 03 Perceuse à percussion
- 04 Mèche Ø 14 mm
- 05 Tournevis
- 06 Marteau
- 07 Pompe de soufflage
- 08 Brosse circulaire en acier
- 09 Pistolet à main
- 10 Tube de rallonge
- 11 Clé pour douille hexagonale
- 12 Perceuse électrique sans fil
- 13 Clé Torx 25
- 14 Aspirateur

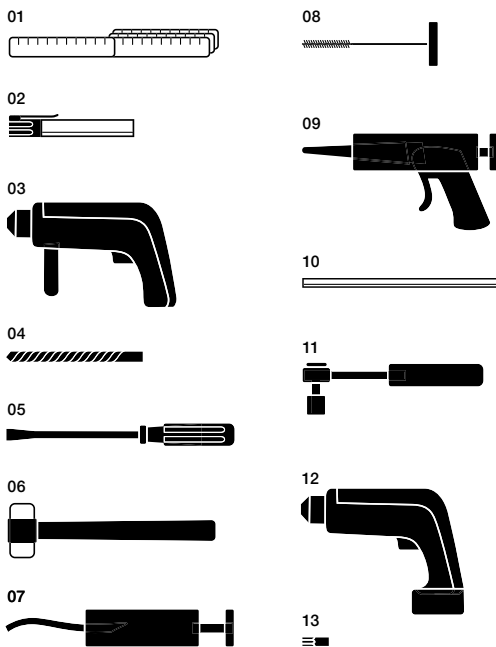

Non inclus dans la livraison.

Outil Jakob*

- 15 Fraise trépaneuse
- 16 Plateaux de fraisage
- 17 Cloche à fraise
- 18 Entraîneur

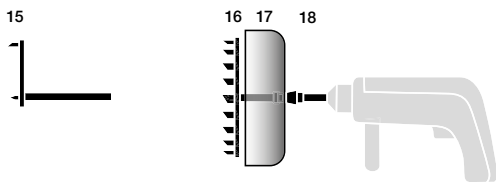

Outil Jakob non inclus. Disponible auprès de votre contact Jakob local : jakob.com (n° 30805-0010). Convient uniquement pour l'isolation en PSE, laine de verre et laine de roche.

Composants GreenBlock 160

- 19 1 × Extension (en option)
N° 30805-0160-...
- 20 1 × Corps de base
N° 30805-0160-...
- 21 3 × Rondelles EPS petites
N° 30805-0125-005
- 22 3 × Écrou anti-desserrage M12
N° 30892-1200-02
- 23 3 × Rondelles
N° 30896-1200-30
- 24 3 × Tiges filetées M12
N° 30882-1200-...
- 25 1 × Mortier composite
N° 30803-0800-05
- 26 1 × Entretoise Webnet
N° 30897-...-00
- 27 3 × Vis à tête hexagonale M12
Nr. 30843-1200-025
- 28 3 × Rondelles M12
N° 30896-1200-30
- 29 3 × Vis de façade à tête bombée
Ø 4,5 mm
N° 30841-0450-080-01
- 30 1 × Tôle de protection
N° 30805-0160-007
- 31 1 × Ruban en butyle (en option)
N° 30805-0160-003

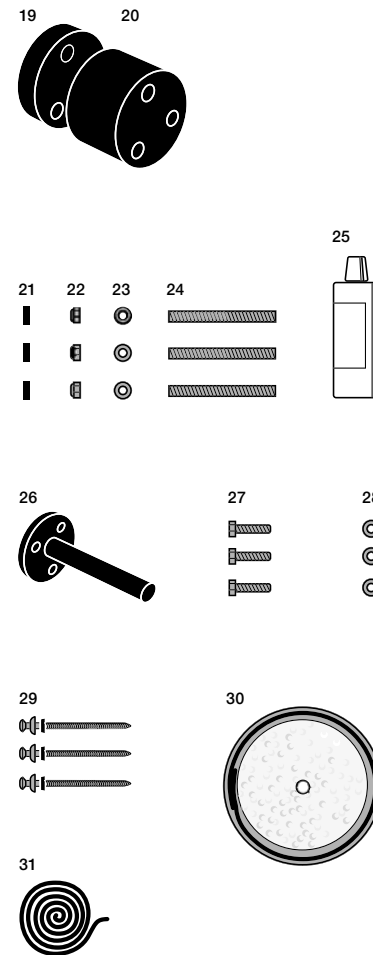

Composants n° 25, 26 et 31 non compris dans la livraison. Disponible auprès de votre contact Jakob local : jakob.com

1

Découper et enlever l'enduit extérieur

- 1.1** Découper l'enduit extérieur avec une fraise trépaneuse et une cloche à fraise à la position indiquée.
- 1.2** Retirer la surface ronde libérée par le découpage avec un outil approprié.

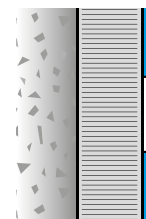
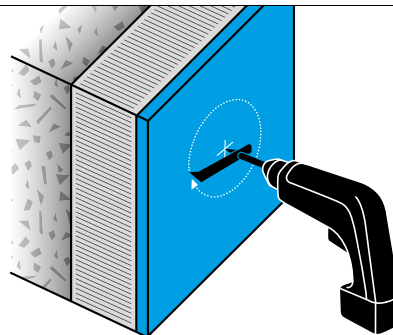

⚠ Ne pas endommager l'enduit extérieur!

2

Fraiser l'isolation

- 2.1** Fraiser l'isolation perpendiculairement à la paroi extérieure avec le plateau de fraisage et la cloche à fraise.

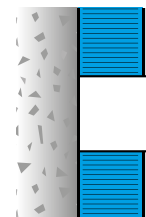
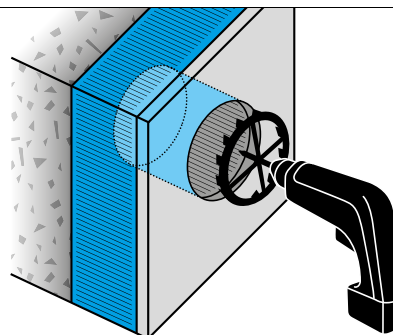

3

Nettoyer et aplanir la surface du béton

- 3.1** Enlever les restes d'isolation de la surface de béton mise à nu.
- 3.2** Enlever les irrégularités.

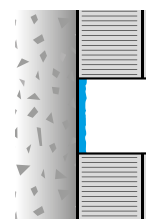
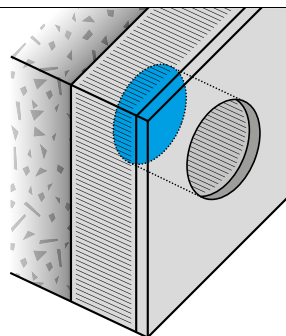

4

Mesurer la cote X

4.1 Mesurer la cote X pour déterminer la profondeur de perçage.

X = _____ mm



La cote X est la distance entre la surface de béton dégagée et le bord extérieur de l'enduit.

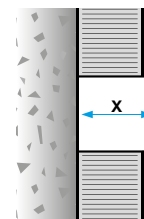
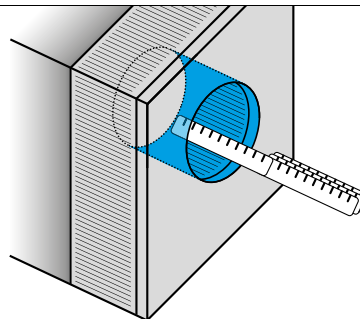

5

Plaquer le mortier d'égalisation avec le corps principal

5.1 Assembler le corps principal avec l'extension (si fourni).

5.2 Appliquer le mortier sur le côté inférieur pour égaliser les inégalités.

5.3 Insérer le corps principal dans le trou et laisser durcir le mortier. Temps de durcissement selon les indications du fabricant.

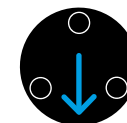
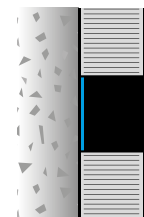
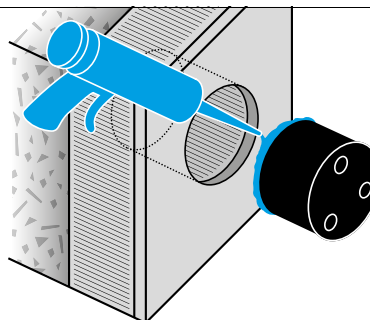

Direction de la charge



Respecter le temps de durcissement!

6

Percer des trous

6.1 Définir la cote L selon le tableau.

6.2 Marquer les forets à la cote L.

6.3 Percer des trous jusqu'à ce que le repère de la mèche soit à la hauteur du bord extérieur de l'enduit.

6.4 Insérer des tiges filetées pour vérifier la profondeur du trou de perçage.

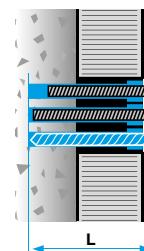
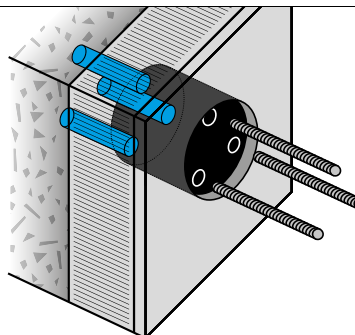

Respecter l'épaisseur minimale de béton selon le tableau!

Cote X (mm)	Cote L (mm)	Épaisseur minimale du béton (mm)	
> 120	245	155	
> 140	270	160	
> 160	297	170	
> 180	325	175	
> 200	351	185	
> 220	378	190	
> 240	405	195	
> 260	X + 161	205	

7

Nettoyer les trous de perçage

- 7.1 Retirer les tiges filetées.
- 7.2 Nettoyer les trous de perçage du mortier d'injection conformément aux indications du produit.

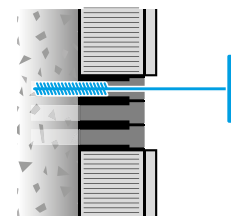
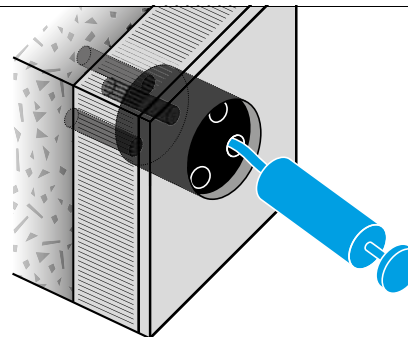

8

Coller les tiges filetées

- 8.1 Visser au minimum l'écrou anti-desserrage sur la tige filetée et enfilez la rondelle sur la tige.
- 8.2 Remplir le premier trou de perçage avec du mortier d'injection.
- 8.3 Visser la tige filetée dans le trou et veiller à ce que la tige filetée ne dépasse pas du corps principal. Laisser durcir le mortier. Temps de durcissement selon les indications du fabricant.
- 8.4 Répéter les étapes 8.1 à 8.3 pour les autres.

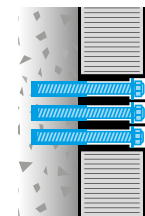
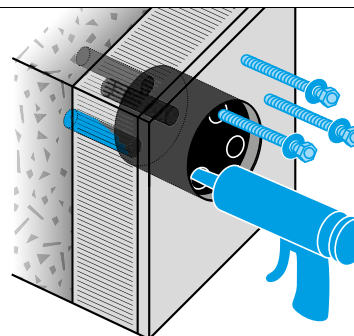

 Respecter le temps de durcissement!

9

Tiges filetées à serrer

- 9.1 Serrer les tiges filetées à un couple de 65 Nm.
- 9.2 Recouvrir les tiges filetées avec des rondelles EPS.

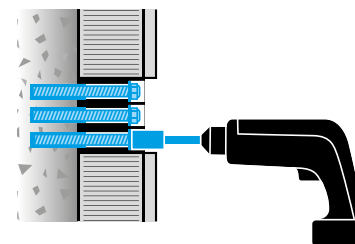
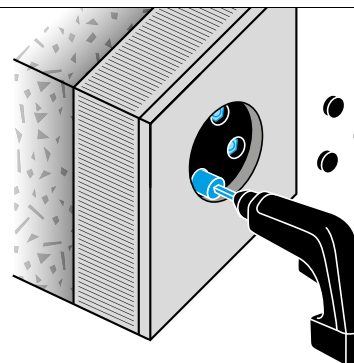

10

Fixer l'entretoise Webnet

10.1 Serrer l'entretoise Webnet à un couple de 65 Nm.

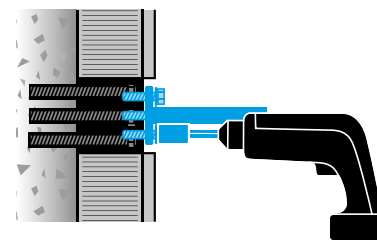
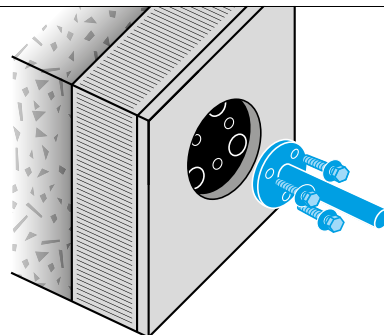

11

Nettoyer la surface de l'enduit

11.1 Nettoyer la surface de l'enduit avec un solvant.
11.2 Pour les enduits bruts, il faut apposer sur la tôle de protection une bande en butyle supplémentaire sur la bande prémontée.



Relier les deux rubans d'étanchéité sans laisser d'espace.

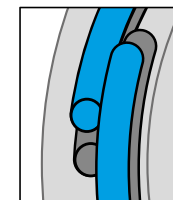
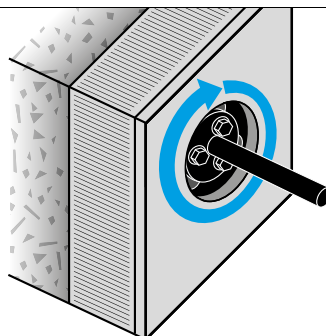

12

Fixer la tôle de protection

12.1 Plaquer la tôle de protection sur l'entretoise.
12.2 Visser la tôle de protection dans les cavités de centrage à l'aide de vis de façade à tête bombée.

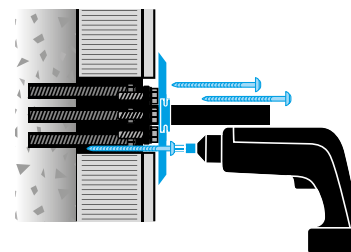
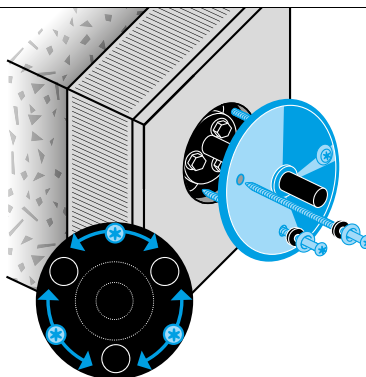

Régler la perceuse sur le régime le plus bas!

Assembly instruction GreenBlock 160

The GreenBlock 160 is a thermally separated high load console, designed to carry the maximum loads of the Webnet spacers.

Installation involves cutting open the existing facade, anchoring the GreenBlock 160 and spacer, and sealing the penetration.

General notes

Ensure that the load-bearing capacity of the substrate is sufficient to accommodate the forces that occur.

Assembly of components by trained personnel only.

No liability is assumed for the necessary safety precautions for proper installation. No responsibility is assumed for the safety and integrity of all persons involved and the surrounding area.

Installation video: [jakob.com](https://www.jakob.com) > Downloads > Videos

Tool

- 01 Double meter
- 02 Marker
- 03 Hammer drill
- 04 Drill Ø 14 mm
- 05 Screwdriver
- 06 Hammer
- 07 Blow out pump
- 08 Steel round brush
- 09 Hand pistol
- 10 Extension tube
- 11 Hexagon nut
- 12 Battery drill
- 13 Torx 25
- 14 Vacuum cleaner

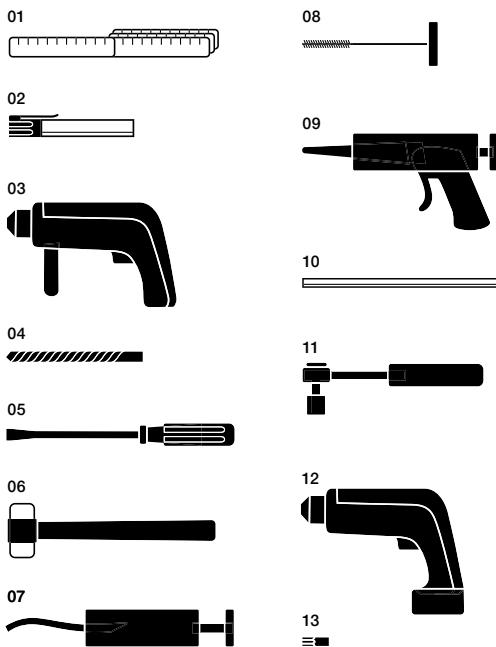

Not included in the scope of delivery.

Tool Jakob*

- 15 Circle cutter
- 16 Milling disc
- 17 Milling bell
- 18 Driver

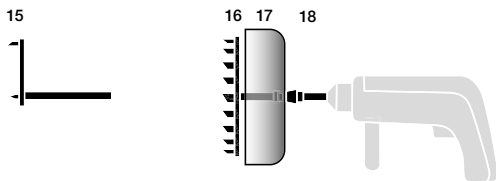

Jakob tool not included in the scope of delivery. Available from your local Jakob contact: jakob.com (No. 30805-0010). Only suitable for EPS, glass and rock wool insulation.

Components GreenBlock 160

- 19 1 × Extension (optional)
No. 30805-0160-...
- 20 1 × Base body
No. 30805-0160-...
- 21 3 × EPS roundels small
No. 30805-0125-005
- 22 3 × Lock nuts M12
No. 30892-1200-02
- 23 3 × Washers
No. 30896-1200-30
- 24 3 × Headless screw M12
No. 30882-1200-...
- 25 1 × Composite mortar
No. 30803-0800-05
- 26 1 × Spacer Webnet
No. 30897-...-00
- 27 3 × Hexagon head screws M12
No. 30843-1200-025
- 28 3 × Washers M12
No. 30896-1200-30
- 29 3 × Countersunk facade screw
Ø 4,5 mm
No. 30841-0450-080-01
- 30 1 × Cover plate
No. 30805-0160-007
- 31 1 × Butyl tape (optional)
No. 30805-0160-003

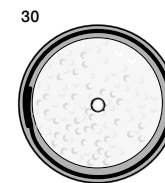
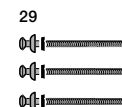
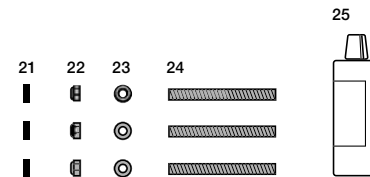
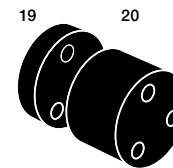

Components no. 25, 26 and 31 not included in delivery. Available from your local Jakob contact: jakob.com

1

Cut open and remove exterior plaster

- 1.1 Cut open the exterior plaster at the indicated position using a circular cutter and a milling bell.
- 1.2 Remove the cut round surface with a suitable tool.

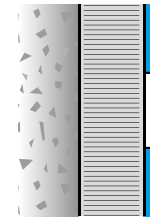
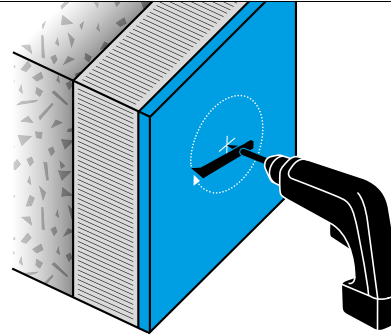

Do not damage the exterior plaster!

2

Mill away insulation

- 2.1 Mill away the insulation at right angles to the outer wall using the milling plate and milling bell.

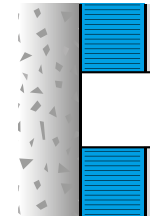
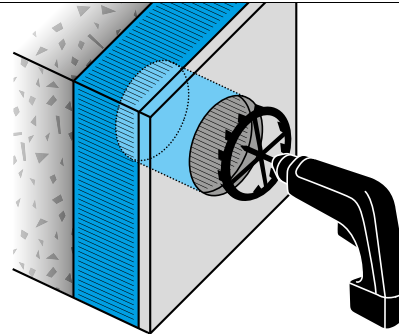

3

Clean and level concrete surface

- 3.1 Remove insulation residues from the exposed concrete surface.
- 3.2 Remove unevenness.

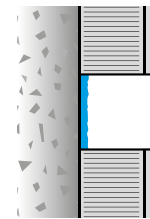
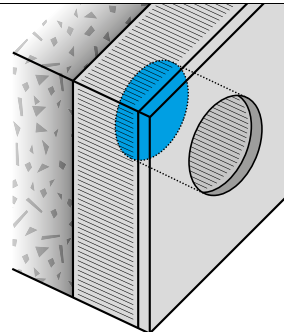

4**Measure X-dimension**

4.1 Measure the X-dimension for determining the drilling depth.

X = _____ mm

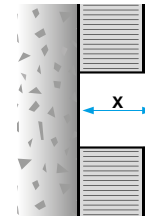
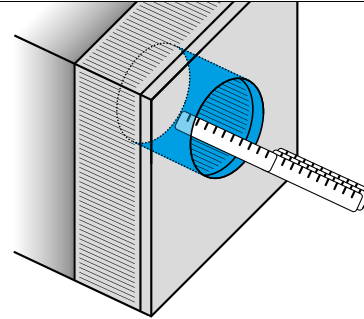

X-dimension is the distance from the exposed concrete surface to the outer edge of the plaster.

**E****5****Place leveling mortar with base body**

- 5.1** Join base body with extension (if supplied).
- 5.2** Apply mortar to underside to level out any unevenness.
- 5.3** Insert the base body into the hole and allow the mortar to set. Hardening time according to manufacturer's instructions.

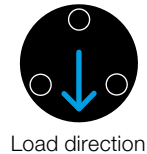
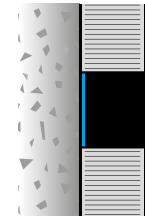
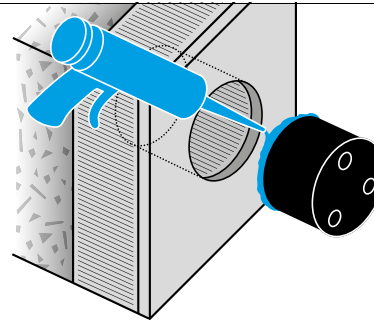

Observe correct hardening time!

6**Drill holes**

- 6.1** Define the L dimension according to the table.
- 6.2** Mark drill bit with L dimension.
- 6.3** Drill holes until the mark from the drill bit is level with the outer edge of the plaster.
- 6.4** Insert headless screw to check drill hole depth.

X dimension (mm)	L dimension (mm)	Minimum concrete thickness (mm)
> 120	245	155
> 140	270	160
> 160	297	170
> 180	325	175
> 200	351	185
> 220	378	190
> 240	405	195
> 260	X + 161	205

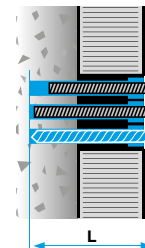
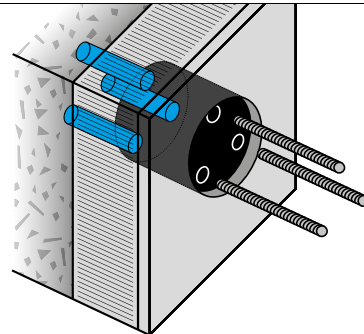

Observe the minimum concrete thickness according to the table!

7

Clean drilled holes

- 7.1 Remove the headless screw.
- 7.2 Clean the drilled holes according to the product instructions of the injection mortar.

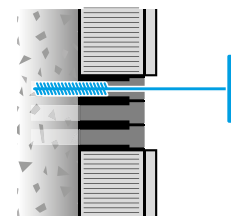
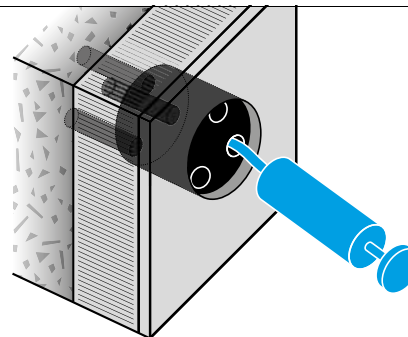

8

Glue in headless screw

- 8.1 Screw the lock nut minimally onto the set screw and put the washer over the set screw.
- 8.2 Fill the first drilled hole with injection mortar.
- 8.3 Screw the set screw into the drilled hole and ensure that the set screw does not protrude beyond the base body. Allow mortar to harden. Hardening time according to manufacturer's instructions.
- 8.4 Repeat steps 8.1–8.3 for the other anchor points.

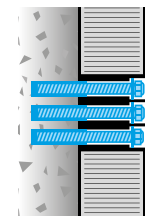
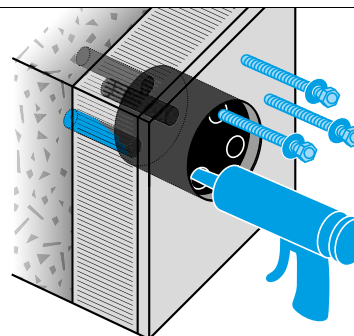

 Observe correct hardening time!

9

Headless screw tightening

- 9.1 Tighten the headless screw to a tightening torque of 65 Nm.
- 9.2 Cover the headless screw with EPS roundels.

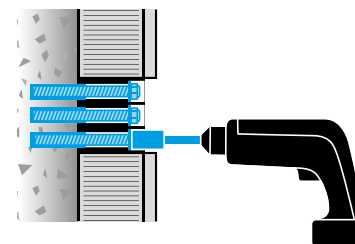
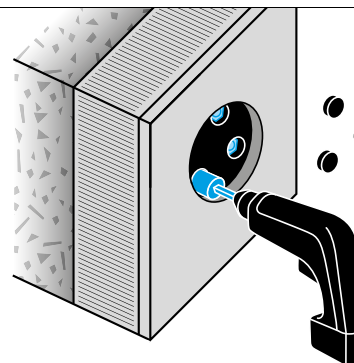

10

Fasten spacer Webnet

10.1 Tighten the spacer Webnet to a tightening torque of 65 Nm.

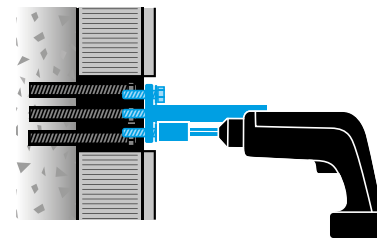
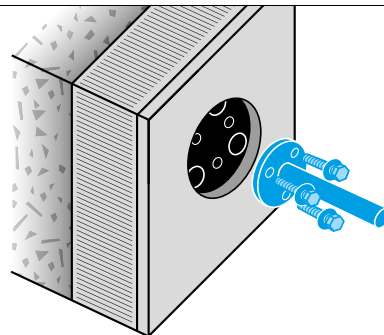

E

11

Clean plaster surface

11.1 Clean the plaster surface with solvent.
11.2 For coarse plaster, an additional butyl tape must be applied to the pre-mounted tape on the cover plate.



Connect the two sealing strips together without gaps.

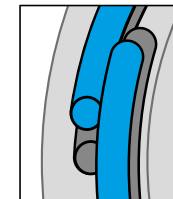
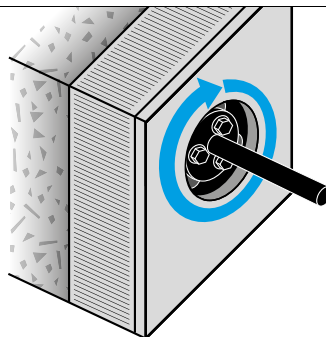

12

Fasten cover plate

12.1 Put the cover plate over the spacer.
12.2 Screw the cover plate into the centering recesses using countersunk facade screw.

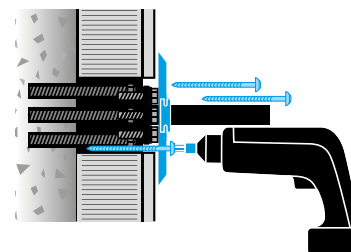
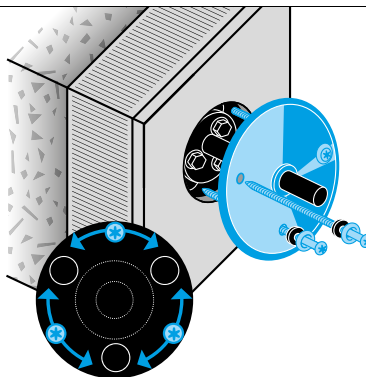

Switch the drilling machine to low speed!

Jakob AG

Dorfstrasse 34
3555 Trubschachen
Switzerland
+41 34 495 10 10
info@jakob.ch

Jakob GmbH

Manfred-Wörner-Strasse 115
73037 Göppingen
Germany
+49 7161 65883 0
info@jakob.eu

Seilerei Wüstner GmbH

Zimmerau 442
6881 Mellau
Austria
+43 5518 2690
office@seil.at

Jakob France SAS

3, rue de l'Artisanat
67240 Bischwiller
France
+33 1 53 25 05 50
info@jakob.fr

Jakob Inc.

119 S H St
FL 33460 Lake Worth Beach
USA
+1 561 330 6502
+1 866 215 1421
info@jakob-usa.com

jakob.com

Jakob
Rope Systems